



C14-M-307

4255

BOARD DIPLOMA EXAMINATION, (C-14)

MARCH/APRIL—2017

DME—THIRD SEMESTER EXAMINATION

MACHINE DRAWING PRACTICE

Time : 3 hours]

[Total Marks : 60

PART—A

5×4=20

Instructions : (1) Answer **all** questions.

(2) Each question carries **five** marks.

(3) All dimensions are to be in mm.

1. Sketch the following thread profiles and label in terms of pitch :

$2\frac{1}{2}+2\frac{1}{2}=5$

(a) Acme thread

(b) Square thread

2. Draw the front and top view of a double riveted chain lap joint and the thickness of each plate to be joined is 9 mm.

$2\frac{1}{2}+2\frac{1}{2}=5$

3. Draw the following weld symbols :

1×5=5

(a) Convex weld

(b) Concave fillet weld

(c) Spot weld

(d) Seam weld

(e) Single-bevel butt weld

4. Draw the symbols for the following pipe fittings (single line) :

1×5=5

(a) Coupling

(b) Plug

(c) 90° elbow

(d) Reducer

(e) Cross

/4255

1

[Contd...

PART—B

40

- Instructions :** (1) Answer *any one* question.
 (2) Each question carries **forty** marks.
 (3) All dimensions are given in mm.
 (4) Choose suitable scale.
 (5) Assume missing dimensions suitably.

5. Draw the front and side view of the socket and Spigot joint in assembly, the details of which are given below :

- (a) Front view 20
 (b) Side view 15
 (c) Dimension 5

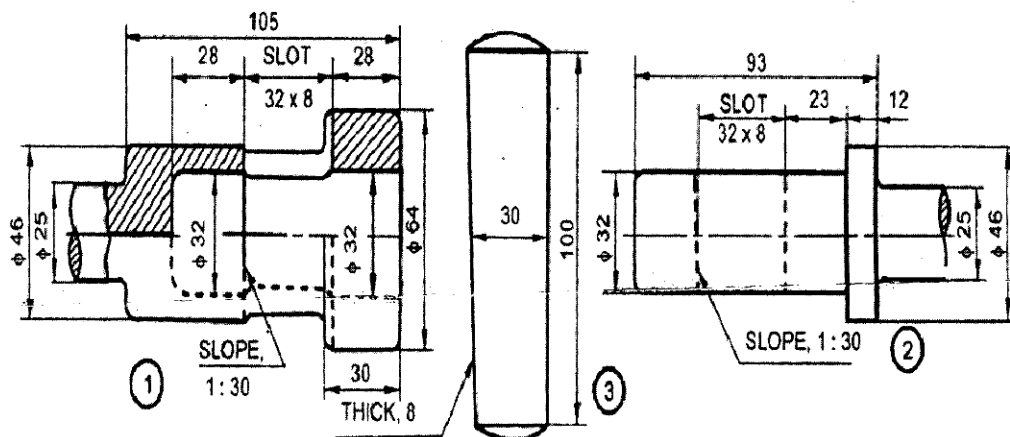

Parts list

No.	Name	Matl	Qty
1	Socket end	MS	1
2	Spigot end	MS	1
3	Cotter	HCS	1

6. Draw the front and top view of the plummer block in assembly, the details of which are given below : 25+10+5=40

